

A-Level Physics Summer Bridging Work 2023/24

Exam board: OCR

Resources that you need to purchase in preparation for studying this course:

- Course textbook: 'A Level Physics for OCR A Student Book (OCR A Level Sciences)'

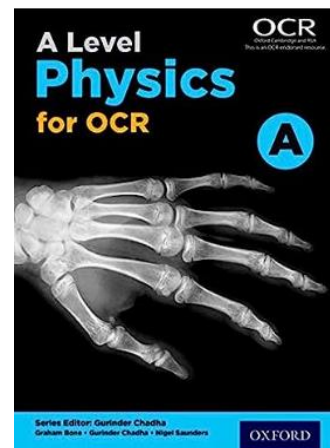

- Lever arch folder for all 3 components of the course
- Section dividers.

Electricity



The questions below are intended to test your knowledge of key ideas covered in most GCSE specifications. Answers with brief explanations follow. You should revise any areas which you find difficult or do not score well on.

Conductors and insulators

- 1 Name three good electrical conductors, including one non-metal.
- 2 Name three electrical insulators.
- 3 What name is given to the property of a material that gives a measure of how easy it is for electrical current to flow through it?
- 4 Why does a circuit stop working when a switch is open?

Circuit symbols

- 5 Copy the table and complete the missing circuit symbols and their names.

symbol	name
	cell
	
	resistor
	
	bulb

Circuits

- 6 Draw a simple circuit containing a cell, bulb, ammeter and voltmeter.
- 7 Label the positive and negative sides of the cell symbol.
- 8 Copy and complete: An ammeter measures flowing in a circuit and is always placed in with components in the circuit.
- 9 Copy and complete: A voltmeter measures across a component and is always placed in with components in the circuit.
- 10 What changes and what remains the same as you move round a series circuit?

Safety

- 11 What are the colours of the mains wires in a plug?
- 12 Name what each wire is.
- 13 Explain how a fuse works.
- 14 If someone is electrocuted what is the first thing you should do?

Calculations

- 15 What is the total resistance when a $470\ \Omega$ resistor is placed in series with a $500\ \Omega$ resistor?
- 16 What is the voltage across a $24\ \Omega$ resistor if a current of $0.78\ \text{A}$ flows through it?
(Use $V = IR$)
- 17 What is the voltage across an $11\ \text{k}\Omega$ resistor if a current of $0.055\ \text{A}$ flows through it? (Use $V = IR$)
- 18 Rearrange $V = IR$ so that current is the subject instead of voltage.
- 19 Calculate the resistance of a circuit if $1.2\ \text{A}$ flows around it when the voltage of the supply is $12\ \text{V}$.
- 20 Calculate the resistance of a resistor if $0.22\ \text{A}$ flows through it when the voltage across it is $230\ \text{V}$.

Forces

The questions below are intended to test your knowledge of key ideas covered in most GCSE specifications. Answers with brief explanations follow. You should revise any areas which you find difficult or do not score well on.

Examples of forces

- 1 What name is given to the force of gravity on an object?
- 2 What is the name of the force that makes raindrops and bubbles round?
- 3 What force between tyres and the surface of a road enables a car to corner?
- 4 What force causes some objects to float in water?
- 5 What name is given to the force acting along a rope that is pulled taut?
- 6 What name is given to the force on the wings of an aeroplane during flight?
- 7 Draw the forces acting on
 - a. a book on a table
 - b. a ball on the floor
 - c. a ball falling towards the ground
 - d. a boat on a still lake

Balanced and unbalanced forces

- 8 What is the name given to the force put on an object by the surface it rests on?
- 9 What is the same, and what is different, about a pair of forces if they are balanced with each other?
- 10 What does it mean to say a body is in equilibrium?
- 11 What does an unbalanced force do to an object's motion?

Newton's Laws of Motion

- 12 State Newton's First Law of Motion.
- 13 Write the formula for Newton's Second Law of Motion.
- 14 What 'saying' is a version of Newton's Third Law of Motion?

Motion

The questions below are intended to test your knowledge of key ideas covered in most GCSE specifications. Answers with brief explanations follow. You should revise any areas which you find difficult or do not score well on.

Speed

- 1 Speed is a measure of how far an object travels in a given time. Write an equation that relates speed, distance and time.
- 2 What is the metric unit for speed?
- 3 What is the average speed of a sprinter, if they travel 200 metres in 19.2 seconds?
- 4 Calculate the average speed of a snail covering 1.6 metres in 26 minutes.
- 5 How far does sound travel in 10 seconds, if its speed in air is 330 ms^{-1} ?
- 6 How long does it take a car travelling at 24 ms^{-1} to cover a distance of 1.2 km?

Acceleration

- 7 Acceleration is the change in speed in a given time. The change in speed is the final speed minus the initial speed, so when the initial speed is zero (that is, when an object starts at rest), the change in speed is the same thing as the final speed. Write an equation that relates acceleration, speed and time.
- 8 Write the metric unit for acceleration.
- 9 If a cyclist reaches a speed of 5 ms^{-1} , after starting from rest, in 3 seconds, what is their acceleration?
- 10 A sprinter achieved a speed of 12 ms^{-1} , 1.4 seconds after the starter's gun was fired. What was their acceleration?
- 11 If an object starting at rest falls with an acceleration of 10 ms^{-2} , what is its speed at 8 seconds?
- 12 How long does it take for a rocket travelling at 100 ms^{-1} to increase its speed to

Force and motion

- 13 Explain the difference between stopping distance, thinking distance and braking distance for vehicles on the road.
- 14 Give three factors that affect thinking distance.
- 15 Give three factors that affect braking distance.
- 16 Name two safety features modern cars have that are designed to reduce the size of forces on occupants during an impact.
- 17 Engine thrust acts forwards when a car is travelling on a road. This is opposed by drag (friction and air resistance) acting in the opposite direction to motion. What happens to these forces:
 - a. when the car accelerates?
 - b. when the car brakes?

Space and Radioactivity

The questions below are intended to test your knowledge of key ideas covered in most GCSE specifications. Answers with brief explanations follow. You should revise any areas which you find difficult or do not score well on.

Space

Earth and moon

- 1 How long does it take for the Earth to rotate on its axis once?
- 2 How long does it take for the moon to orbit the Earth once?
- 3 How many people have landed on the moon?
- 4 Why do you need a space suit on the moon?
- 5 Why is the strength of gravity lower on the moon's surface than on Earth's?
- 6 What advantage do telescopes mounted on satellites in orbit have over ground-based telescopes?

Solar system

- 7 Who is credited with first suggesting that the Earth orbits the sun?
- 8 What name is given to the model of the solar system where planets orbit the sun?
- 9 List the four gas giant planets in our solar system.
- 10 Place the following planets in order of surface temperature from highest to lowest: Earth,

Stars

- 11 What is the nearest star to Earth?
- 12 Approximately how far, in light years, is the next nearest star?
- 13 What force causes stars to form?
- 14 What process powers stars?
- 15 What type of star do stars like the Sun become as they start burning helium?
- 16 Very large stars end their short 'lives' in a huge explosion called a supernova. What extreme object can be formed from the core of the exploding star?

Radioactivity

Atoms and isotopes

- 17 Write the relative charges of the electron, proton and neutron.
- 18 Write the relative masses of the electron, proton and neutron.
- 19 Deuterium is an isotope of hydrogen. What is different between hydrogen and deuterium?
- 20 Carbon-12 has a nucleon number of 12 and a proton number of 6. How many neutrons does it have in its nucleus?

Alpha, beta and gamma

- 21 Write the relative charges of alpha, beta and gamma radiation.
- 22 Write the relative masses of alpha, beta and gamma radiation.
- 23 What happens to an isotope when it emits alpha or beta radiation?
- 24 Why is exposure to radiation dangerous?

Sources and uses of radiation

- 25 Name three sources of background radiation.
- 26 Describe how radioactive tracers are used in medicine.
- 27 Explain why smoke detectors work with alpha radiation but why beta or gamma radiation would not be suitable.
- 28 What process happens in a nuclear power plant, and what is the usual fuel?